

## N-Channel Enhancement Mode MOSFET

### Features

- High Speed Power Switching
- Reliable and Rugged
- ROHS Compliant
- 100% Avalanche Tested

### Applications

- Power Management in Desktop Computer
- DC/DC Converters

### Pin Description

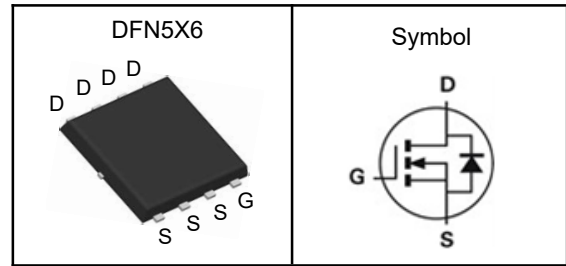

$V_{DSS}$	100	V
$R_{DS(ON)-Typ}$	4.3	m $\Omega$
$I_D$	120	A

### Absolute Maximum Ratings ( $T_C=25^\circ\text{C}$ , Unless Otherwise Noted)

Symbol	Parameter	Rating	Unit
$V_{DSS}$	Drain-Source Voltage	100	V
$V_{GSS}$	Gate-Source Voltage	$\pm 20$	V
$T_J$	Maximum Junction Temperature	-55 to 150	$^\circ\text{C}$
$T_{STG}$	Storage Temperature Range	-55 to 150	$^\circ\text{C}$
EAS	Single Pulse Avalanche Energy <sup>③</sup>	295	mJ
$I_{DM}^{①}$	Pulse Drain Current Tested	480	A
$I_D$	Continuous Drain Current	$T_C=25^\circ\text{C}$	A
$P_D$	Maximum Power Dissipation	$T_C=25^\circ\text{C}$	W

### Thermal Characteristics

Symbol	Parameter	Rating	Unit
$R_{\theta JA}$	Thermal Resistance-Junction to Ambient	62	$^\circ\text{C}/\text{W}$
$R_{\theta JC}$	Thermal Resistance Junction-Case <sup>①</sup>	0.58	$^\circ\text{C}/\text{W}$

Note ① : Max. current is limited by bonding wire.

Note ② : UIS tested and pulse width are limited by maximum junction temperature  $150^\circ\text{C}$ .

Note ③ : Surface Mounted on  $1\text{in}^2$  FR-4 board with 1oz.

**N-Channel Enhancement Mode MOSFET****Electrical Characteristics** ( $T_J=25^{\circ}\text{C}$ , Unless Otherwise Noted)

Symbol	Parameter	Test Conditions	Min	Typ	Max	Unit
<b>Static Electrical Characteristics</b>						
$BV_{DSS}$	Drain-Source Breakdown Voltage	$V_{GS}=0V, I_D=250\mu A$	100	---	---	V
$I_{DSS}$	Zero Gate Voltage Drain Current	$V_{DS}=100V, V_{GS}=0V$	---	---	1	$\mu A$
$V_{GS(th)}$	Gate Threshold Voltage	$V_{DS}=V_{GS}, I_D=250\mu A$	2.0	3.0	4.0	V
$I_{GSS}$	Gate Leakage Current	$V_{GS}=\pm 20V, V_{DS}=0V$	---	---	$\pm 100$	nA
$R_{DS(on)}$	Drain-Source On-state Resistance	$V_{GS}=10V, I_D=20A$	---	4.3	5.3	m $\Omega$
<b>Dynamic Characteristics</b> <sup>⑤</sup>						
$C_{iss}$	Input Capacitance	$V_{DS}=25V, V_{GS}=0V, \text{Freq.}=1\text{MHz}$	---	3050	---	pF
$C_{oss}$	Output Capacitance		---	1632	---	
$C_{rss}$	Reverse Transfer Capacitance		---	65	---	
$T_{d(on)}$	Turn-on Delay Time	$V_{DD}=80V, V_{GS}=10V, I_D=30A, R_G=20\Omega$	---	6	---	nS
$T_r$	Turn-on Rise Time		---	82	---	
$T_{d(off)}$	Turn-off Delay Time		---	28	---	
$T_f$	Turn-off Fall Time		---	93	---	
$Q_g$	Total Gate Charge	$V_{DS}=50V, V_{GS}=10V, I_D=80A$	---	42	---	nC
$Q_{gs}$	Gate-Source Charge		---	15	---	
$Q_{gd}$	Gate-Drain Charge		---	11	---	
<b>Source-Drain Characteristics</b>						
$V_{SD}$	Diode Forward Voltage	$I_S=20A, V_{GS}=0V$	---	---	1.1	V
$t_{rr}$	Reverse Recovery Time	$I_F=30A, V_{DD}=80V, \text{d}I_F/\text{d}t=100A/\mu s$	---	5	---	nS
$Q_{rr}$	Reverse Recovery Charge		---	0.5	---	nC

Note ④: Pulse test (pulse width $\leq 300\mu s$ , duty cycle $\leq 2\%$ ).

Note ⑤: Guaranteed by design, not subject to production testing.

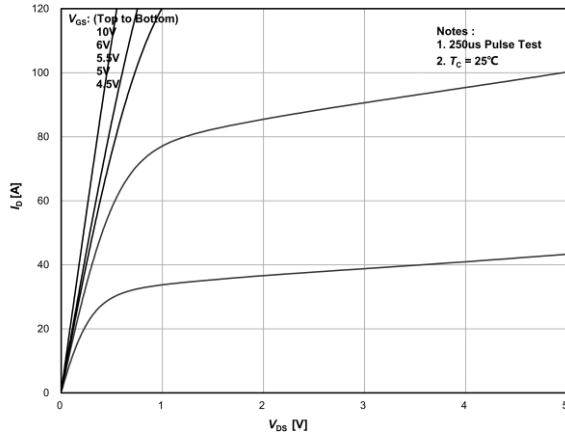
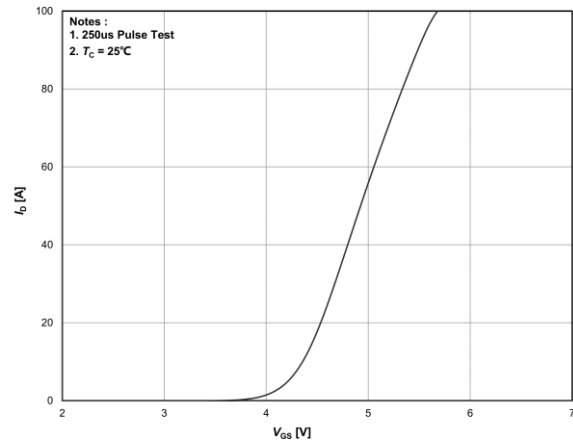
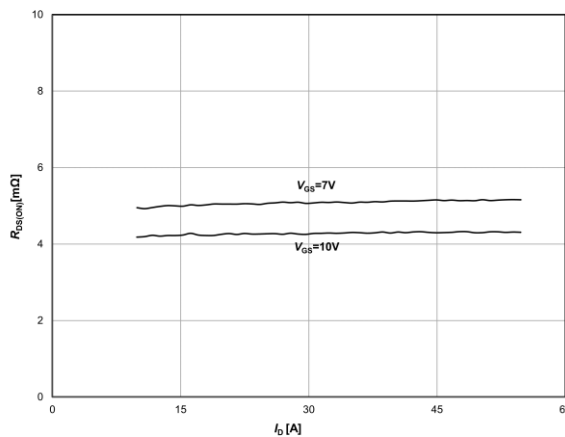
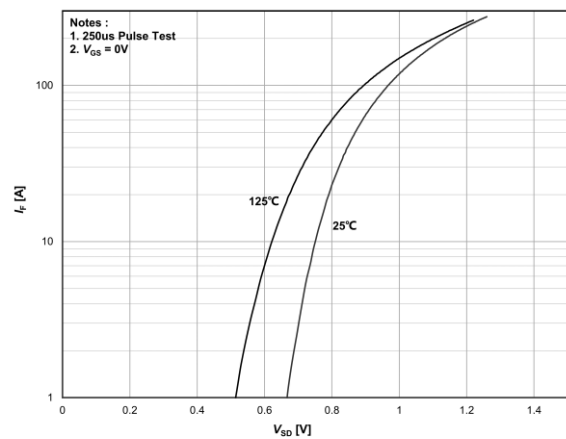
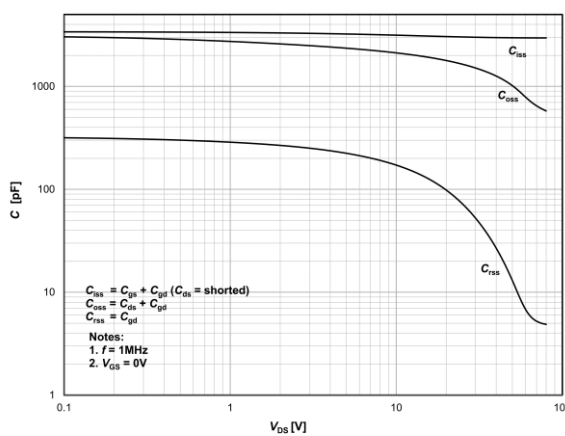
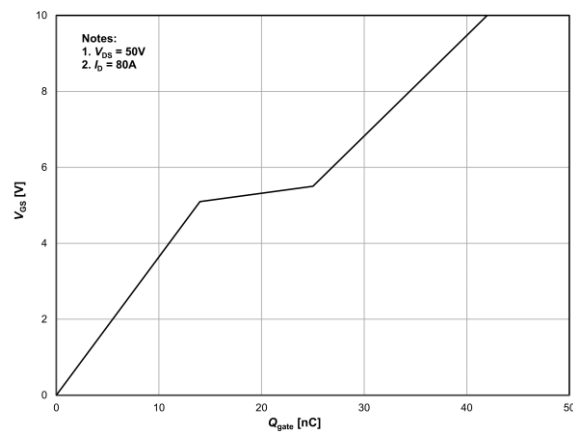
**N-Channel Enhancement Mode MOSFET**
**Typical Characteristics**

**Figure 1. On-Region Characteristics**

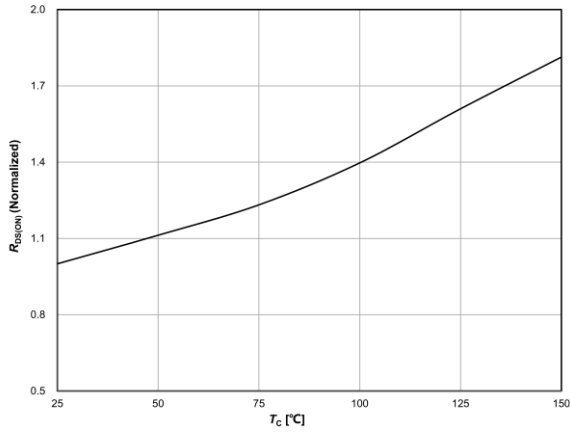
**Figure 2. Transfer Characteristics**

**Figure 3. On-Resistance Variation vs Drain Current and Gate Voltage**

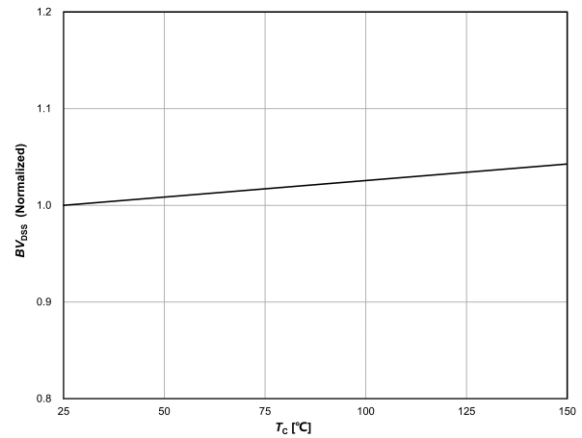
**Figure 4. Body Diode Forward Voltage Variation with Source Current**

**Figure 5. Capacitance Characteristics**

**Figure 6. Gate Charge Characteristics**

**N-Channel Enhancement Mode MOSFET**



**Figure 7. On-Resistance Variation vs Temperature**



**Figure 8. Breakdown Voltage Variation vs Temperature**

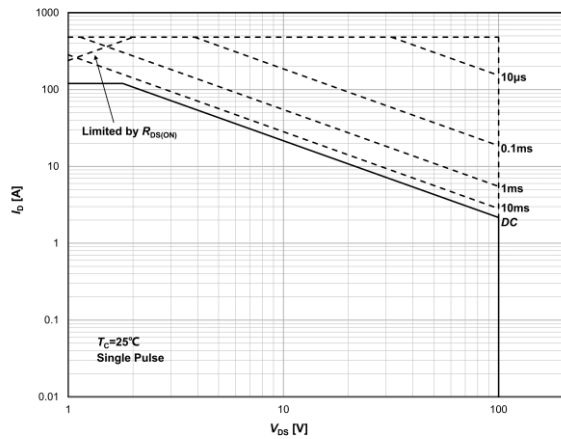

**Figure 9. Maximum Safe Operating Area<sup>3)</sup>**

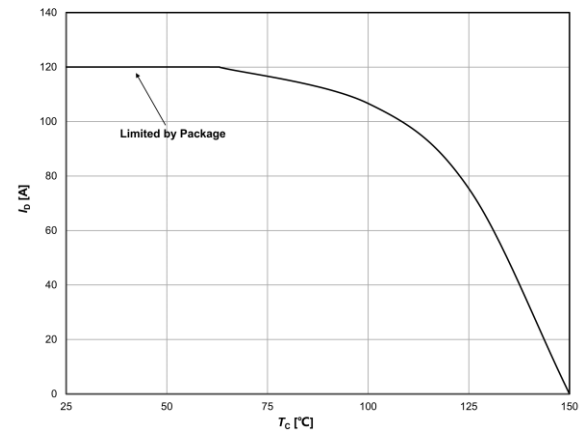

**Figure 10. Maximum Continuous Drain Current vs Case Temperature**

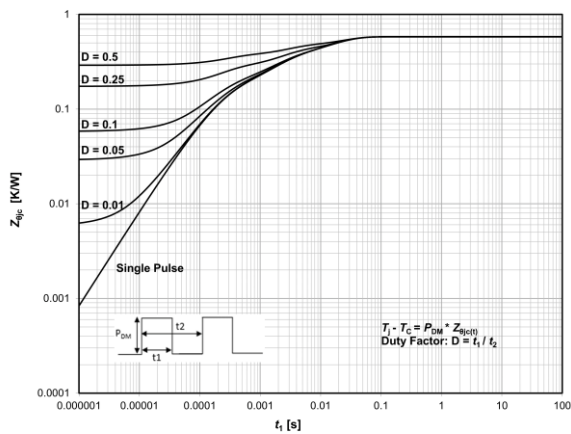

**Figure 11. Transient Thermal Response Curve**

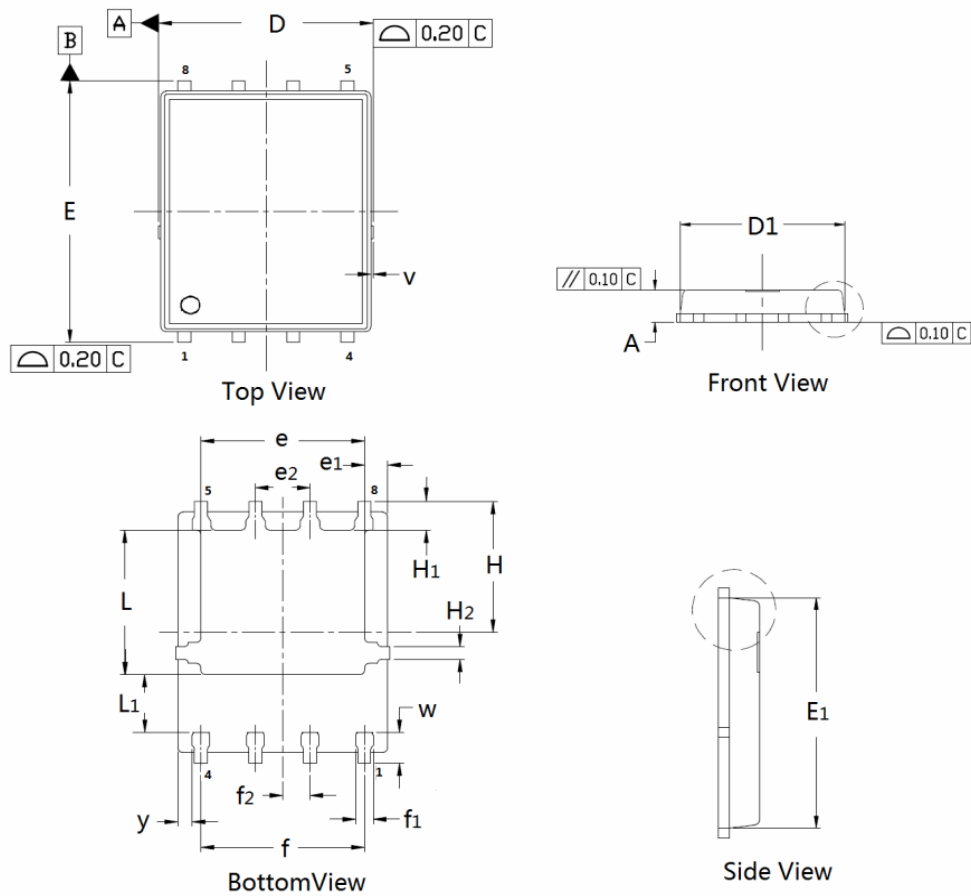
**N-Channel Enhancement Mode MOSFET**
**DFN5×6 Package Outline Data**

**DIMENSIONS ( unit : mm )**

Symbol	Min	Typ	Max	Symbol	Min	Typ	Max
A	0.90	1.02	1.10	D	4.90	4.98	5.10
D <sub>1</sub>	4.80	4.89	5.10	E	5.90	6.11	6.25
E <sub>1</sub>	5.65	5.74	5.95	e	3.72	3.80	3.92
e <sub>1</sub>	--	0.5	--	e <sub>2</sub>	--	1.	--
f	--	3.8	--	f <sub>1</sub>	0.31	0.37	0.51
f <sub>2</sub>	--	0.6	--	H	--	3.	--
H <sub>1</sub>	0.59	0.63	0.79	H <sub>2</sub>	0.26	0.28	0.32
L	3.35	3.45	3.65	L <sub>1</sub>	--	1.	--
v	--	0.1	--	w	0.64	0.68	0.84
y	--	0.3	--		--		--