

N-Channel Enhancement Mode MOSFET

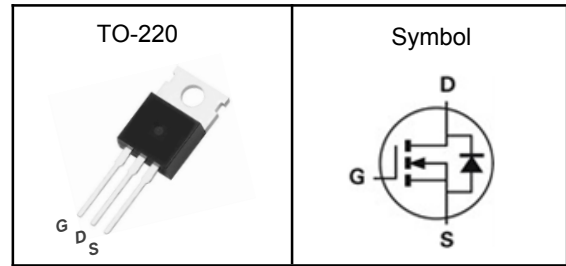
Features

- Advanced SGT technology
- High Speed Power Switching
- Reliable and Rugged
- ROHS Compliant
- 100% Avalanche Tested

Applications

- Power Management in Desktop Computer
- DC/DC Converters

Pin Description



V_{DSS}	100	V
$R_{DS(ON)-Typ}$	3.9	m Ω
I_D	145	A

Absolute Maximum Ratings ($T_J=25^\circ\text{C}$, Unless Otherwise Noted)

Symbol	Parameter		Rating	Unit
V_{DSS}	Drain-Source Voltage		100	V
V_{GSS}	Gate-Source Voltage		± 20	V
T_J	Maximum Junction Temperature		-55 to 150	$^\circ\text{C}$
T_{STG}	Storage Temperature Range		-55 to 150	$^\circ\text{C}$
E_{AS}	Single Pulse Avalanche Energy		320	mJ
$I_{DM}^{①}$	Pulse Drain Current Tested		580	A
I_D	Continuous Drain Current	$T_C=25^\circ\text{C}$	145	A
	Continuous Drain Current	$T_C=100^\circ\text{C}$	92	A
P_D	Maximum Power Dissipation	$T_C=25^\circ\text{C}$	208	W

Thermal Characteristics

Symbol	Parameter	Rating	Unit
$R_{\theta JA}^{③}$	Thermal Resistance-Junction to Ambient	58	$^\circ\text{C}/\text{W}$
$R_{\theta JC}$	Thermal Resistance, Junction-to-Case	0.6	$^\circ\text{C}/\text{W}$

Note ① : Max. current is limited by bonding wire.

Note ② : UIS tested and pulse width are limited by maximum junction temperature 150 $^\circ\text{C}$.

Note ③ : Surface Mounted on 1in² FR-4 board with 1oz.



N-Channel Enhancement Mode MOSFET

Electrical Characteristics ($T_J=25^{\circ}\text{C}$, Unless Otherwise Noted)

Symbol	Parameter	Test Conditions	Min	Typ	Max	Unit
Static Electrical Characteristics						
BV_{DSS}	Drain-Source Breakdown Voltage	$V_{GS}=0V, I_D=250\mu A$	100	---	---	V
I_{DSS}	Zero Gate Voltage Drain Current	$V_{DS}=100V, V_{GS}=0V$	---	---	1	μA
$V_{GS(th)}$	Gate Threshold Voltage	$V_{DS}=V_{GS}, I_D=250\mu A$	2.0	---	4.0	V
I_{GSS}	Gate Leakage Current	$V_{GS}=\pm 20V, V_{DS}=0V$	---	---	± 100	nA
$R_{DS(on)}$	Drain-Source On-state Resistance	$V_{GS}=10V, I_D=20A$	---	3.9	4.5	m Ω
gfs	Forward Transconductance	$V_{DS}=10V, I_D=20A$	---	62	---	S
Dynamic Characteristics ^⑤						
C_{iss}	Input Capacitance	$V_{GS}=0V,$ $V_{DS}=50V,$ Freq.=1.0MHz	---	5350	---	pF
C_{oss}	Output Capacitance		---	740	---	
C_{rss}	Reverse Transfer Capacitance		---	21	---	
$T_{d(on)}$	Turn-on Delay Time	$V_{GS}=10V, V_{DD}=50V,$ $I_D=20A, R_G=3\Omega$	---	21	---	nS
T_r	Turn-on Rise Time		---	36	---	
$T_{d(off)}$	Turn-off Delay Time		---	51	---	
T_f	Turn-off Fall Time		---	32	---	
Q_g	Total Gate Charge	$V_{GS}=10V, V_{DD}=50V,$ $I_D=20A$	---	98	---	nC
Q_{gs}	Gate-Source Charge		---	22	---	
Q_{gd}	Gate-Drain Charge		---	32	---	
Source-Drain Characteristics						
V_{SD}	Diode Forward Voltage	$I_S=20A, V_{GS}=0V$	---	---	1.2	V
t_{rr}	Reverse recovery time	$I_F=20A,$ $diF/dt=100A/\mu s$	---	58	---	nS
Q_{rr}	Reverse recovery charge		---	81	---	nC

Note ④ : Pulse test (pulse width \leq 300us, duty cycle \leq 2%).

Note ⑤ : Guaranteed by design, not subject to production testing.

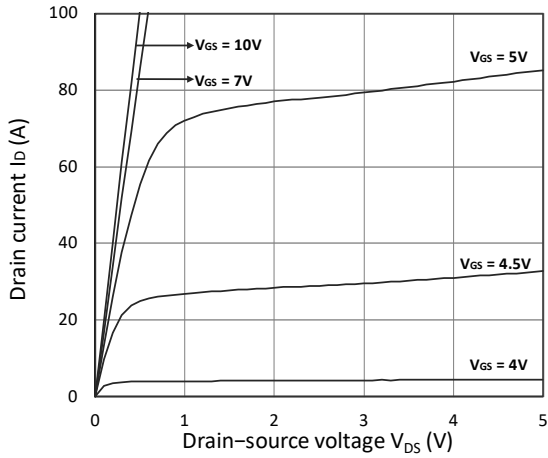
N-Channel Enhancement Mode MOSFET
Typical Characteristics


Figure 1. Output Characteristics

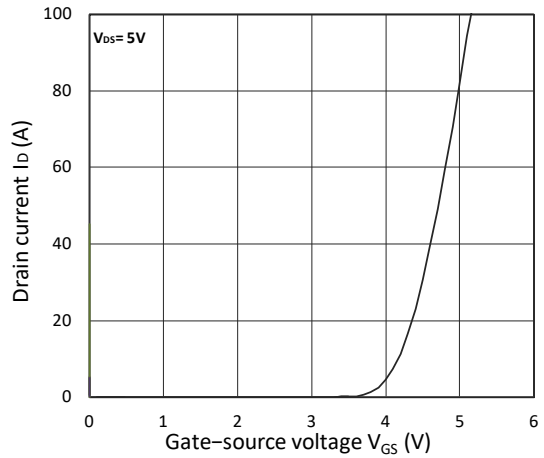


Figure 2. Transfer Characteristics

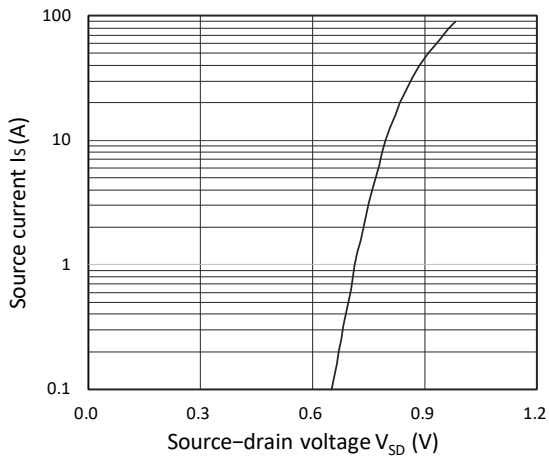
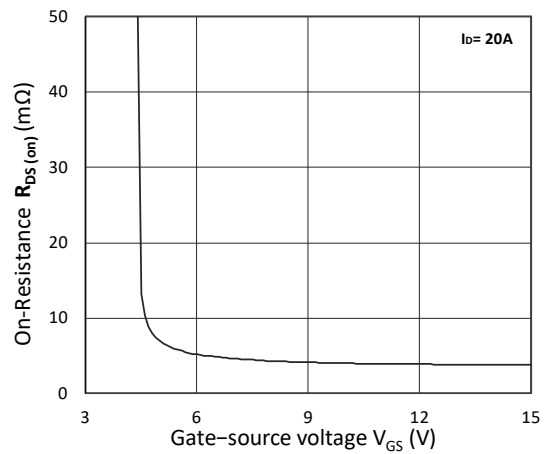
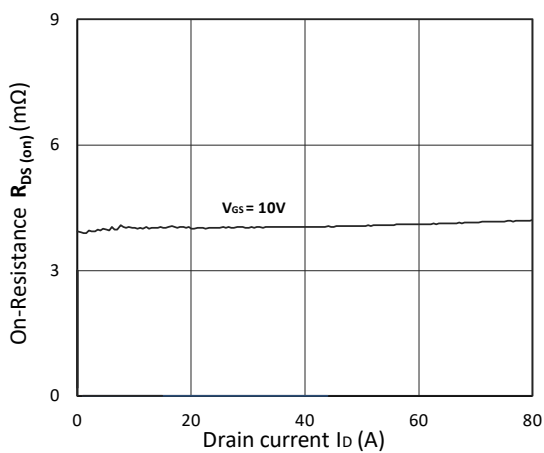
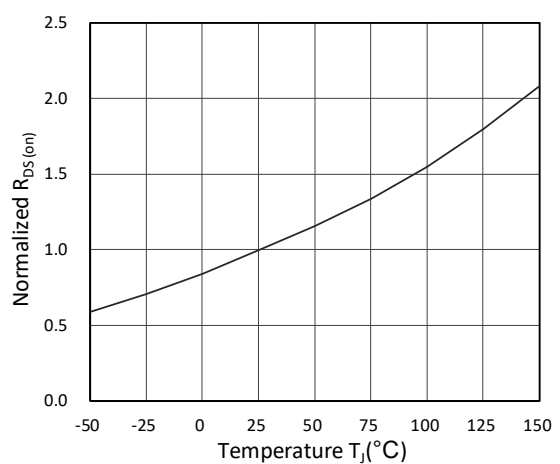


Figure 3. Forward Characteristics of Reverse


 Figure 4. $R_{DS(on)}$ vs. V_{GS}

 Figure 5. $R_{DS(on)}$ vs. I_D

 Figure 6. Normalized $R_{DS(on)}$ vs. Temperature

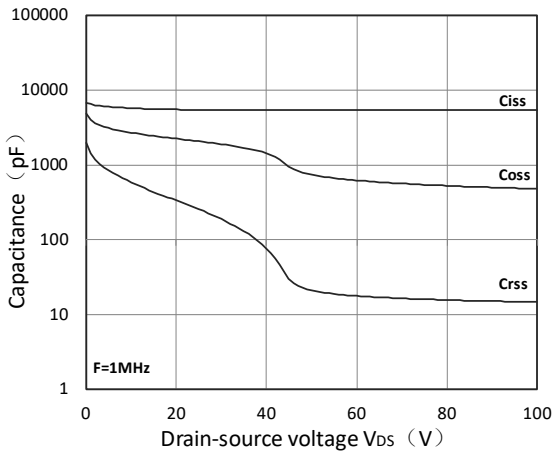
N-Channel Enhancement Mode MOSFET


Figure 7. Capacitance Characteristics

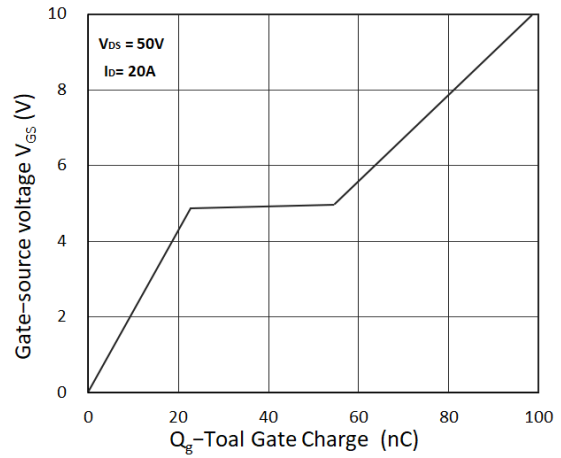


Figure 8. Gate Charge Characteristics

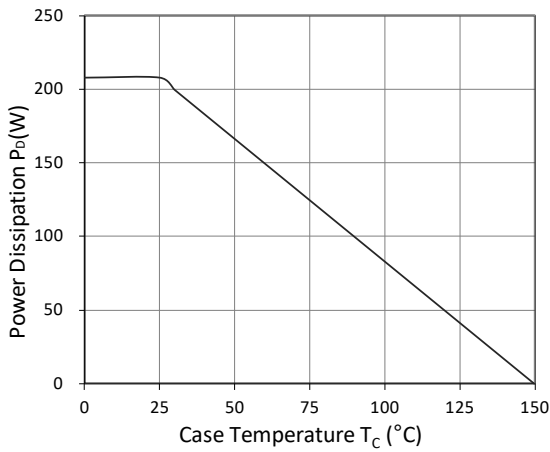


Figure 9. Power Dissipation

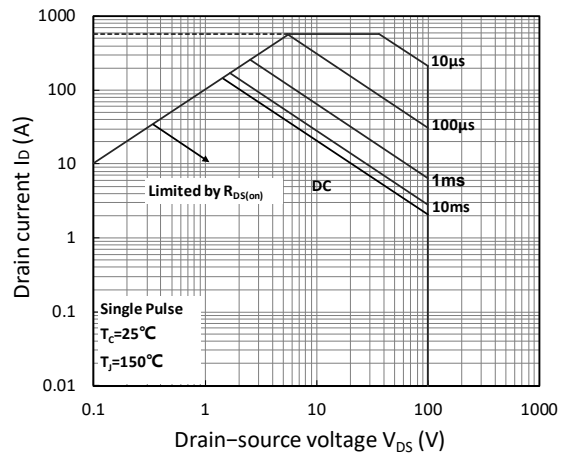


Figure 10. Safe Operating Area

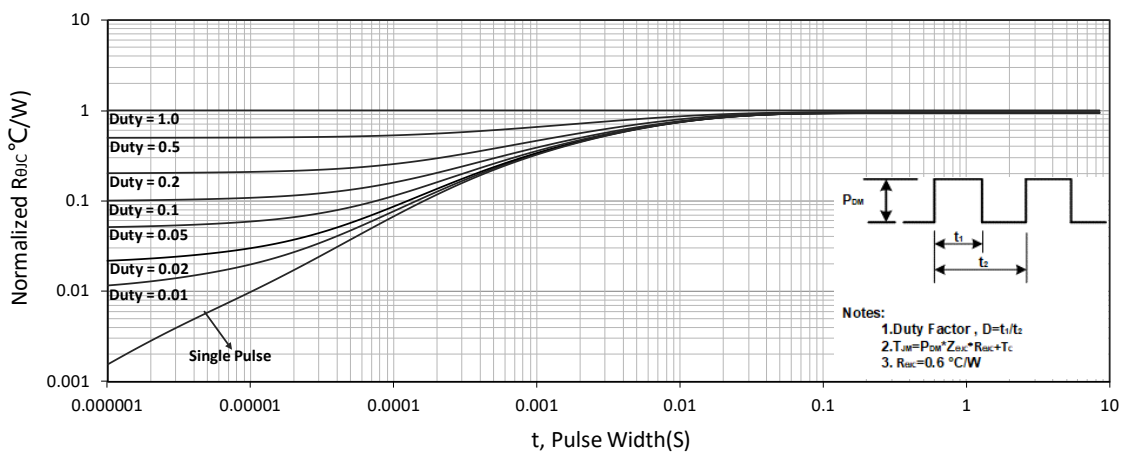
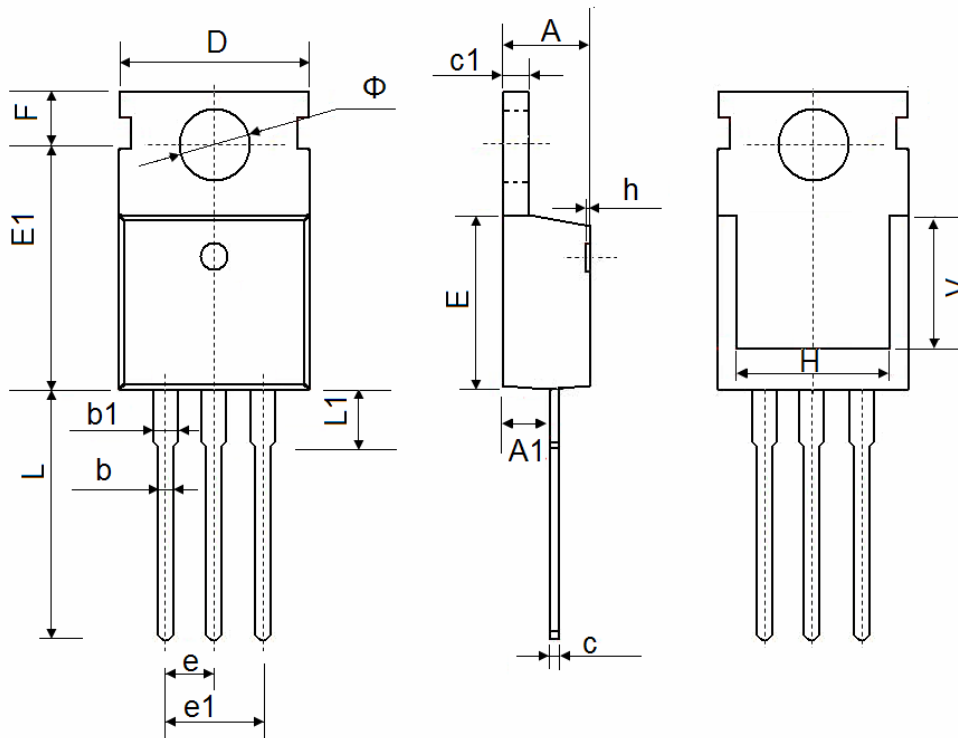


Figure 11. Normalized Maximum Transient Thermal Impedance

N-Channel Enhancement Mode MOSFET
TO-220 Package Outline Data


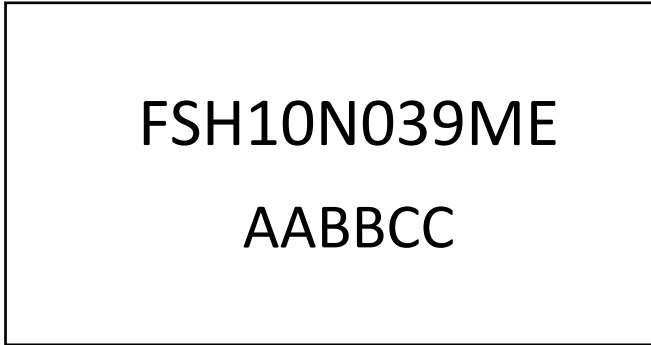
Symbol	Dimensions In Millimeters	
	Min.	Max.
A	4.350	4.650
A1	2.250	2.550
b	0.710	0.910
b1	1.170	1.400
c	0.330	0.650
c1	1.200	1.400
D	9.910	10.250
E	8.9500	9.750
E1	12.650	12.950
e	2.540 TYP.	
e1	4.980	5.180
F	2.650	2.950
H	7.900	8.100
h	0.000	0.300
L	12.700	13.500
L1	2.850	3.250
V	7.500 REF.	
Φ	3.400	3.800



N-Channel Enhancement Mode MOSFET

印字说明

印字说明



第一行标记为物料型号代码

第二行为AA为内部识别码，BB为表示年份，例如22即表示2022年，CC表示周期，例如01即表示第一周；
2201即表示2022年第一周生产。