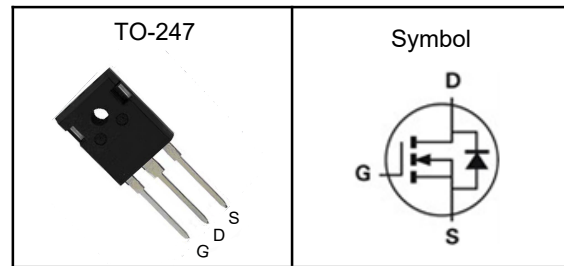

600V Super Junction Power MOSFET
Features

- Low drain-source on-resistance: $R_{DS(ON)}=0.025\Omega$ (typ)
- Very Low FOM ($R_{DS(on)} \times Q_g$)
- Extremely low switching loss
- 100% avalanche tested
- RoHS compliant

Applications

- Switch Mode Power Supply (SMPS)
- TV power & LED Lighting Power
- AC to DC Converters
- Telecom

Pin Description

V_{DSS}	600	V
$R_{DS(ON)-Typ}$	25	m Ω
I_D	90	A

Absolute Maximum Ratings ($T_J=25^\circ\text{C}$, Unless Otherwise Noted)

Symbol	Parameter	Rating	Unit
V_{DSS}	Drain-Source Voltage	600	V
V_{GSS}	Gate-Source Voltage	± 30	V
T_J	Maximum Junction Temperature	-55 to 150	$^\circ\text{C}$
T_{STG}	Storage Temperature Range	-55 to 150	$^\circ\text{C}$
E_{AS}	Single Pulse Avalanche Energy ³	414	mJ
$I_{DM}^{①}$	300 μs Pulse Drain Current Tested	270	A
I_D	Continuous Drain Current	$T_C=25^\circ\text{C}$ 90	A
P_D	Maximum Power Dissipation	$T_C=25^\circ\text{C}$ 500	W

Thermal Characteristics

Symbol	Parameter	Rating	Unit
$R_{\theta JA}$	Thermal Resistance Junction-Ambient ¹	62	$^\circ\text{C}/\text{W}$
$R_{\theta JC}$	Thermal Resistance Junction-Case ¹	0.25	$^\circ\text{C}/\text{W}$

Note ① : Max. current is limited by bonding wire.

Note ② : UIS tested and pulse width are limited by maximum junction temperature 150 $^\circ\text{C}$.

Note ③ : Surface Mounted on 1in² FR-4 board with 1oz.



600V Super Junction Power MOSFET

Electrical Characteristics ($T_J=25^{\circ}\text{C}$, Unless Otherwise Noted)

Symbol	Parameter	Test Conditions	Min	Typ	Max	Unit
Static Electrical Characteristics						
BV_{DSS}	Drain-Source Breakdown Voltage	$V_{GS}=0V, I_D=250\mu A$	600	---	---	V
I_{DSS}	Zero Gate Voltage Drain Current	$V_{DS}=600V, V_{GS}=0V$	---	---	5	μA
$V_{GS(th)}$	Gate Threshold Voltage	$V_{DS}=V_{GS}, I_D=250\mu A$	3.0	---	5.0	V
I_{GSS}	Gate Leakage Current	$V_{GS}=\pm 30V, V_{DS}=0V$	---	---	± 100	nA
$R_{DS(ON)}$	Drain-Source On-state Resistance	$V_{GS}=10V, I_D=28A$	---	25	29	$m\Omega$
Dynamic Characteristics ^⑤						
C_{iss}	Input Capacitance	$V_{GS}=0V,$ $V_{DS}=400V,$ $Freq.=1MHz$	---	8000	---	pF
C_{oss}	Output Capacitance		---	166	---	
C_{riss}	Reverse Transfer Capacitance		---	0.44	---	
$T_{d(on)}$	Turn-on Delay Time	$V_{DD}=400V,$ $R_G=3.4\Omega, I_D=28A$	---	33	---	nS
T_r	Turn-on Rise Time		---	55	---	
$T_{d(off)}$	Turn-off Delay Time		---	147	---	
T_f	Turn-off Fall Time		---	6.4	---	
Q_g	Total Gate Charge	$V_{DS}=400V,$ $V_{GS}=10V,$ $I_D=28A$	---	153	---	nC
Q_{gs}	Gate-Source Charge		---	37.6	---	
Q_{gd}	Gate-Drain Charge		---	54.9	---	
Source-Drain Characteristics ($T_J=25^{\circ}\text{C}$)						
V_{SD} ^④	Diode Forward Voltage	$I_F=1A, V_{GS}=0V$	---	---	0.63	V
t_{rr}	Reverse Recovery Time	$V_R=400V, I_F=28A, di/dt=100A/\mu s, T_J=25^{\circ}\text{C}$	---	180	---	nS
Q_{rr}	Reverse Recovery Charge		---	1.62	---	nC

Note ④ : Pulse test (pulse width $\leq 300\mu s$, duty cycle $\leq 2\%$).

Note ⑤ : Guaranteed by design, not subject to production testing.

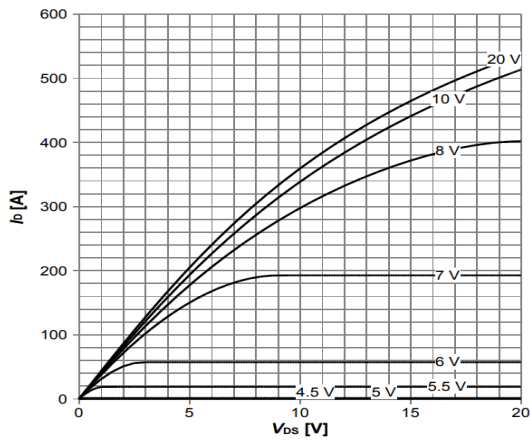
600V Super Junction Power MOSFET
输出特性
Diagram 1: Typ. output characteristics

$$I_D = f(V_{DS}); T_j = 25\text{ }^\circ\text{C}; \text{parameter: } V_{GS}$$

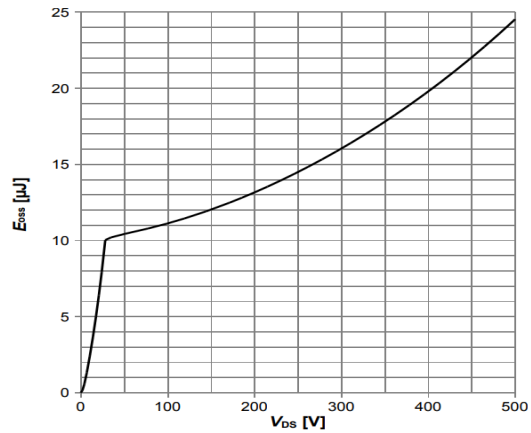
Diagram 2: Typ. Coss stored energy

$$E_{oss} = f(V_{DS})$$

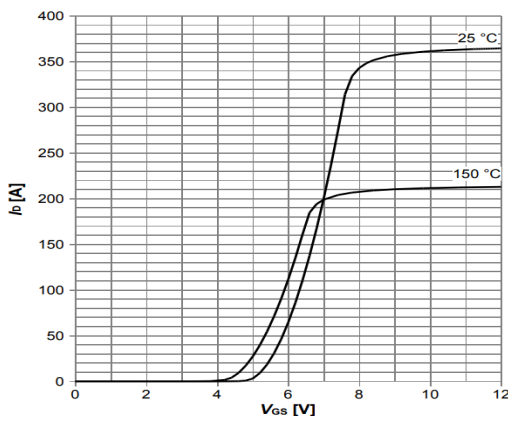
Diagram 3: Typ. transfer characteristics

$$I_D = f(V_{GS}); \text{parameter: } T_j$$

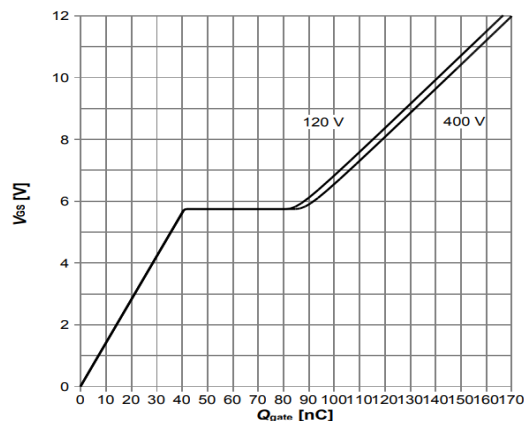
Diagram 4: Typ. gate charge

$$V_{GS} = f(Q_{gate}); I_D = 28\text{A pulsed}; \text{parameter: } V_{DD}$$

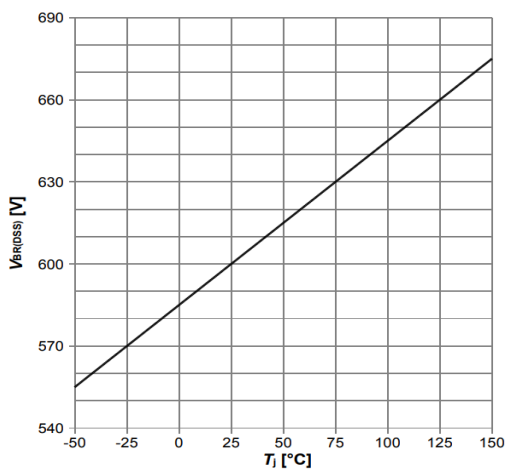
Diagram 5: Drain-source breakdown voltage

$$V_{BR(DSS)} = f(T_j); I_D = 1\text{mA}$$

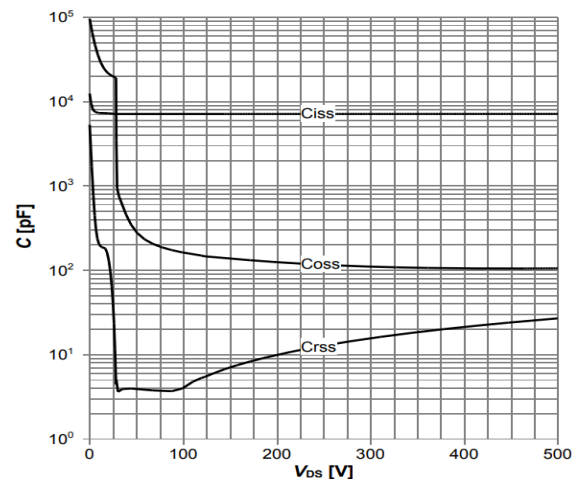
Diagram 6: Typ. capacitances

$$C = f(V_{DS}); V_{GS} = 0\text{V}; f = 1\text{MHz}$$

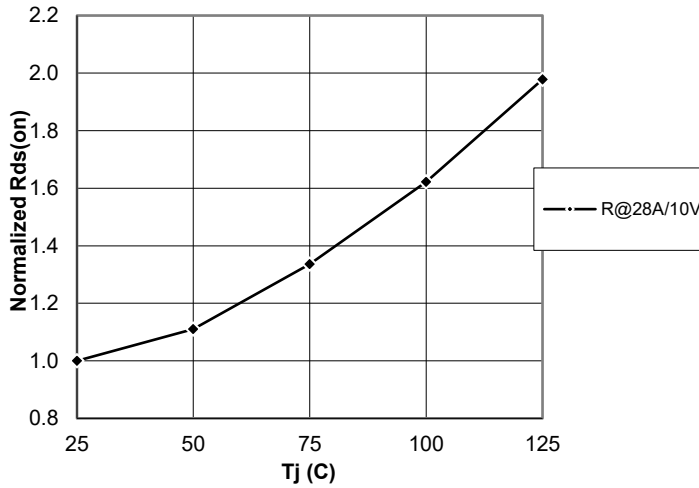
600V Super Junction Power MOSFET
Diagram 7: Typ. On-Resistance vs. Junction Temperature

$$R_{ds(on)} = f(T_j); V_{gs} = 10V / I_b = 28A$$

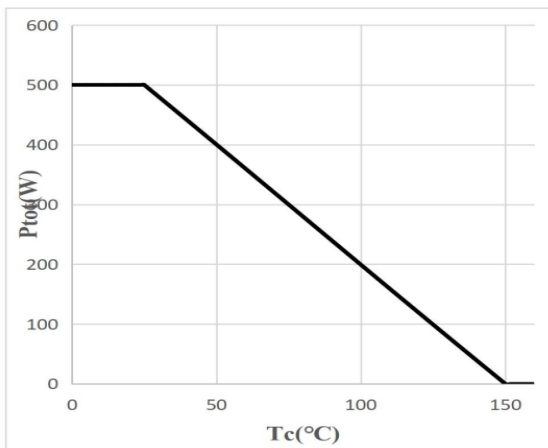
Diagram 9: Typ. Power Dissipation

$$P_{tot} = f(T_c)$$

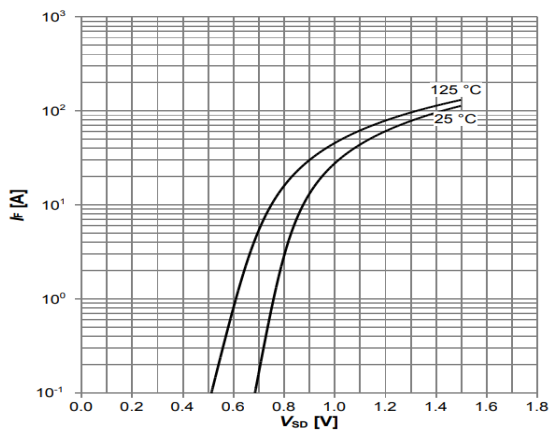
Diagram 11: Forward characteristics of reverse diode

$$I_f = f(V_{ds}); \text{parameter: } T_j$$

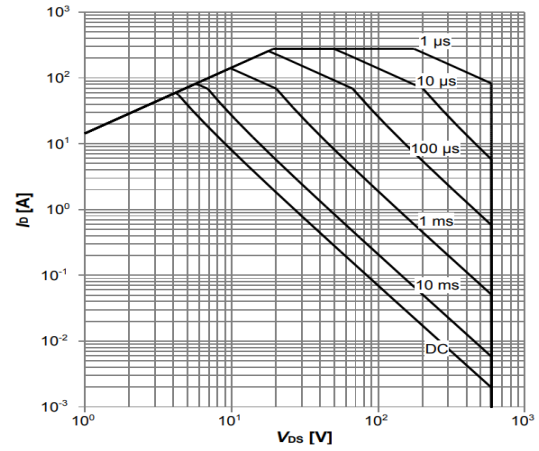
Diagram 8: Safe operating area T_c=25 °C, TO247

$$I_D = f(V_{DS}); T_c = 25^\circ\text{C}; V_{GS} > 7V; D = 0; \text{parameter } t_p$$

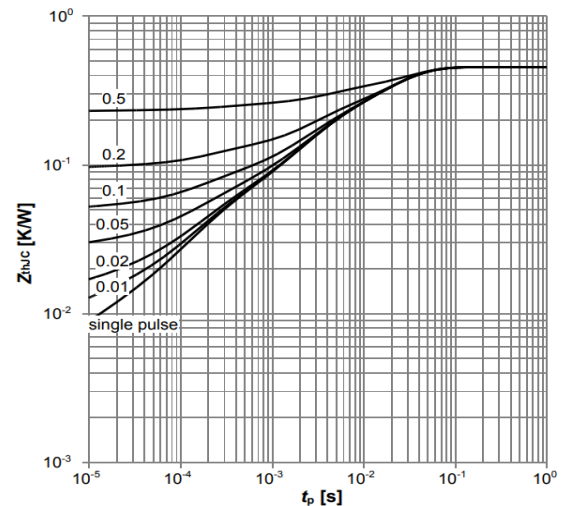
Diagram 10: Max. transient thermal impedance

$$Z_{thJC} = f(t_p); \text{parameter: } D = t_p / T$$

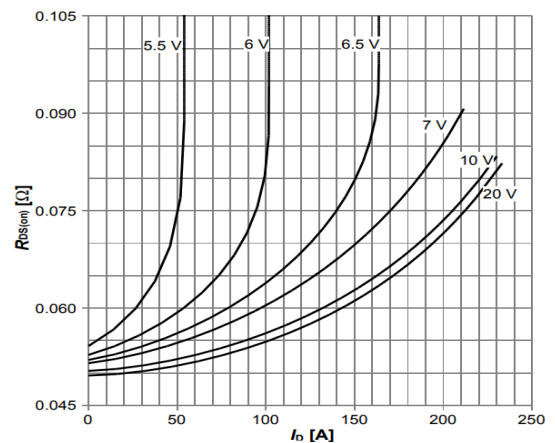
Diagram 12: Typ. Drain-source on-state resistance

$$R_{ds(on)} = f(T_j); T_j = 125^\circ\text{C}, \text{Parameter: } V_{gs}$$

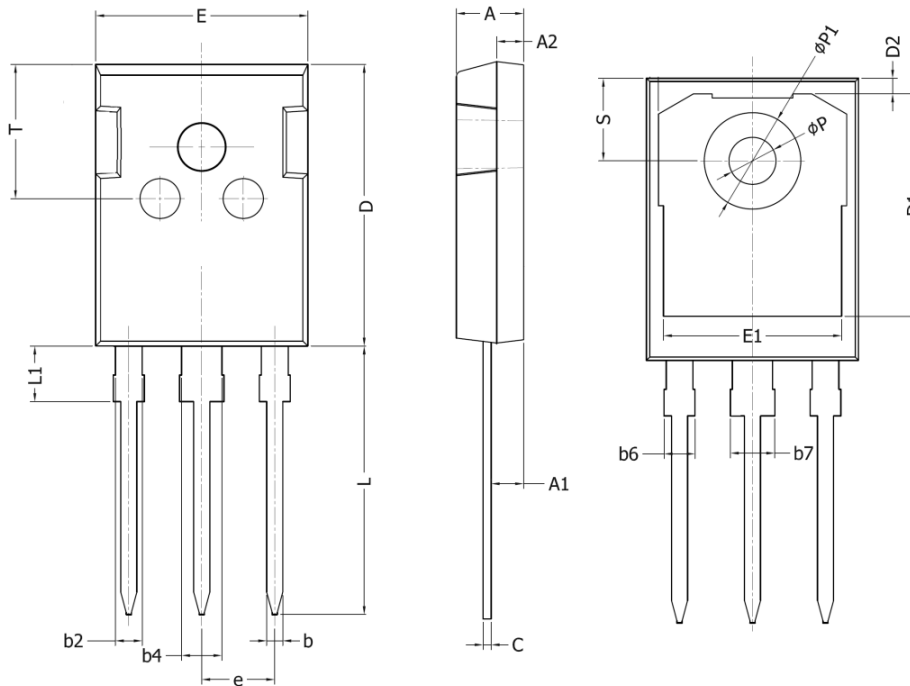
600V Super Junction Power MOSFET
TO-247 Package Outline Dimensions

Symbol	Dimensions In Millimeters	
	Min.	Max.
A	4.90	5.20
A1	2.31	2.51
A2	1.9	2.1
b	1.16	1.26
b2	1.96	2.06
b4	2.96	3.06
b6	-	2.25
b7	-	3.25
C	0.59	0.66
D	20.90	21.20
D1	16.25	16.85
D2	1.05	1.35
E	15.75	16.10
E1	13.00	13.60
e	5.436 BSC	
L	19.80	20.20
L1	-	4.30
P	3.40	3.60
P1	7.00	7.40
S	6.05	6.25
T	9.80	10.20